



NORTH TRAMPOLINE LOW

ASSEMBLY MANUAL / MONTAGEANLEITUNG

ROUND | 430 | 360 | 300

NTR324322-22 : Round 430 Black Low
NTR324322-24 : Round 430 Petrol Low
NTR323622-22 : Round 360 Black Low
NTR323622-24 : Round 360 Petrol Low
NTR323022-22 : Round 300 Black Low
NTR323022-24 : Round 300 Petrol Low

OVAL | 500 | 420 | 350

NTO125022-22 : Oval 500 Black Low
NTO125022-24 : Oval 500 Petrol Low
NTO124222-22 : Oval 420 Black Low
NTO124222-24 : Oval 420 Petrol Low
NTO123522-22 : Oval 350 Black Low
NTO123522-24 : Oval 350 Petrol Low



NORTH TRAMPOLINE LOW

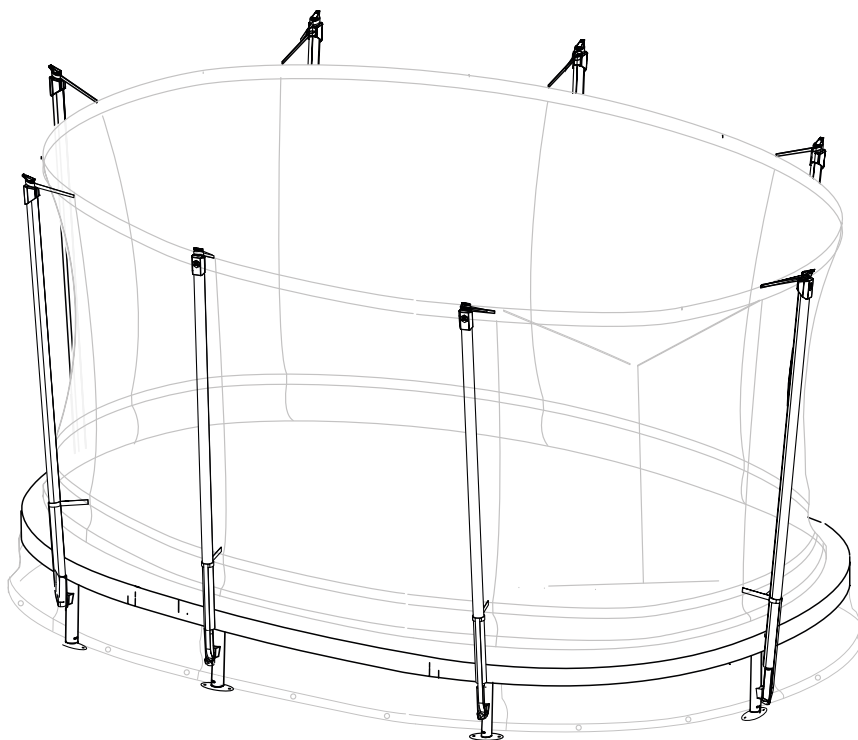

ROUND | 430 | 360 | 300

OVAL | 500 | 420 | 350

All rights reserved 2022. Avero AB ©

All artwork and illustrations are owned by Avero AB, Sweden.

Copying or reusing them is prohibited by law.

For more information, contact us at info@northtrampoline.com

Alle Rechte vorbehalten 2022. Avero AB ©

Alle Grafiken und Illustrationen sind im Besitz von Avero AB, Schweden.

Deren Kopieren oder Weiterverwendung ist gesetzlich verboten.

Kontaktieren Sie uns unter info@northtrampoline.com

um weitere Informationen zu erhalten.



**ENG:
WARNING**

This trampoline requires a hole to be dug BEFORE it can be used. Jumping before digging a correct hole can cause serious injury. Check that the hole is intact frequently to avoid possible injury.

**SV:
VARNING**

Du måste gräva ett hål INNAN du använder den här studs mattan. Hoppning innan det finns ett ordentligt hål kan leda till allvarliga skador. Kontrollera regelbundet att hålet är intakt för att undvika skador.

**NO:
ADVARSEL**

Denne trampolinen krever at det graves et hull FØR trampolinen kan tas i bruk. Følg anvisningene for hvordan hullet skal graves og kontroller at hullet er intakt og i orden i henhold til manualen før bruk for å unngå eventuelle skader.

**DK:
ADVARSEL**

Denne trampolin kræver, at der graves et hul, FØR den kan anvendes. At hoppe, før der er gravet et korrekt hul, kan medføre alvorlig skade. Kontroller hyppigt, at hullet er intakt for at undgå eventuel skade.

**FI:
VAROITUS**

Tälle trampoliinille on kaivettava kuoppa ENNEN kuin sitä voi käyttää. Matolla hyppiminen ennen oikeanlaisen kuopan kaivamista voi aiheuttaa vakavia loukkaantumisia. Tarkasta, että kuoppa on kunnossa, mahdollisten loukkaantumisten välttämiseksi.

**DE:
WARNUNG**

Dieses Trampolin erfordert, dass eine Vertiefung/Erdaushub gegraben wird, bevor es benutzt werden kann. Wird gesprungen, ohne dass zuvor eine ordnungsgemäße Vertiefung hergestellt worden ist, besteht die Gefahr schwerer Verletzungen. Überprüfen Sie häufig, ob die Vertiefung intakt ist, um möglichen Verletzungen vorzubeugen.

ASSEMBLY INSTRUCTIONS / MONTAGEANLEITUNG

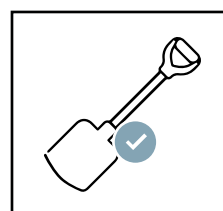
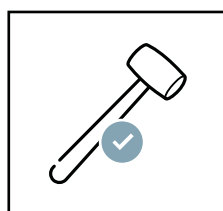
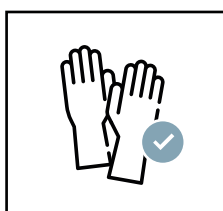
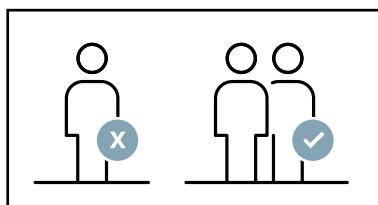

ENG

This is a parts list for your trampoline. If you find any piece missing please contact your local dealer.

SV

Detta är en förteckning på studs mattans delar. Skulle ni sakna någon del, vänligen kontakta er närmaste återförsäljare.

NO

Dette er en liste over tilhørende din trampoline. Hvis noe mangler, vennligst ta kontakt med din lokale forhandler.

DK

Liste over alle de dele, som udgør din trampolin. Kontakt venligst din forhandler, hvis du opdager, at noget mangler.

FI

Ohessa trampoliinisi osaluettelo. Jos jokin osa puuttuu, ota yhteyttä paikalliseen jälleenmyyjään.

DE

Dies ist die Teileliste für Ihr Trampolin. Wenn Sie feststellen, dass Teile fehlen, wenden Sie sich bitte an Ihren Händler.

ROUND

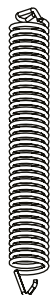

300: x64
360: x80
430: x96

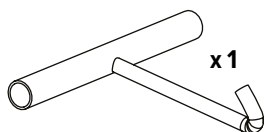

x1

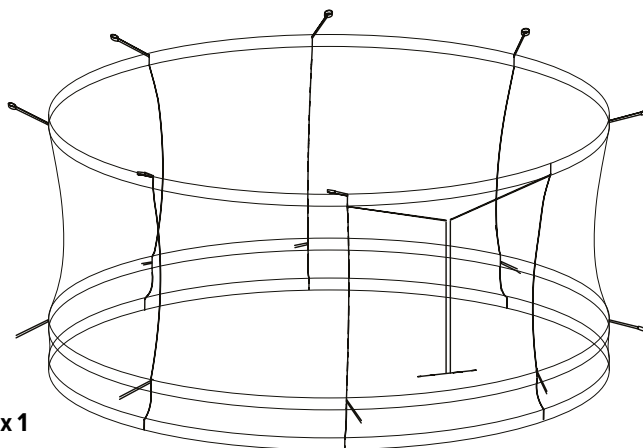

x1



x8



300: x64
360: x80
430: x96

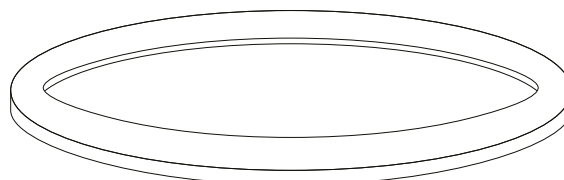

x1

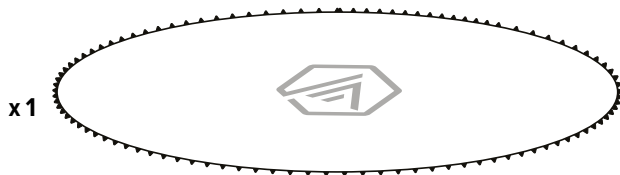

x1

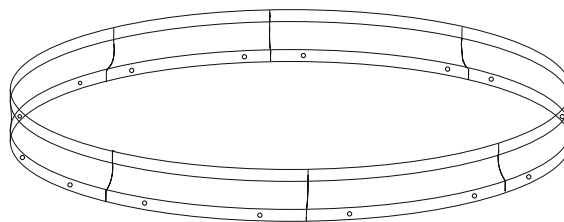

x1



x16



x16



x8



x8



x8

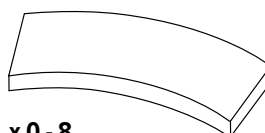

x0-8

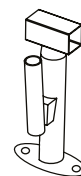

x8



x42



x8

OVAL 



350: x64
420: x80
500: x96

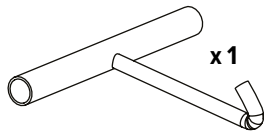

x1



x8



350: x64
420: x80
500: x96

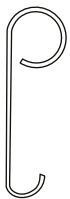

x16

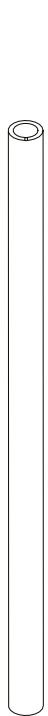

x16



x8



x8



x8

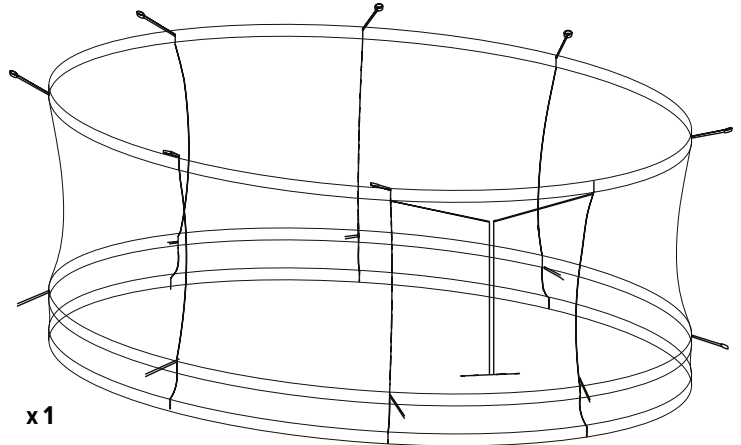

x1

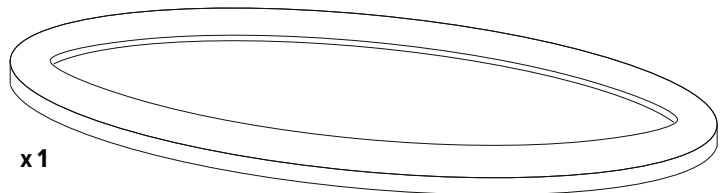

x1

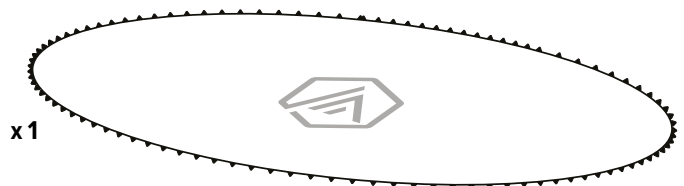

x1

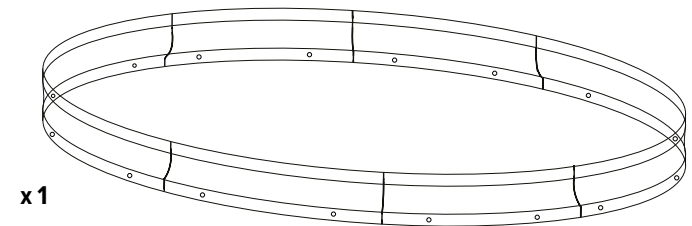

x1



x0-8

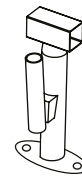

x8



x42

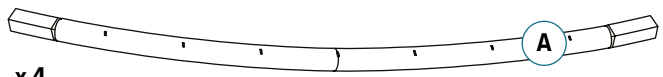

x4



x4

1

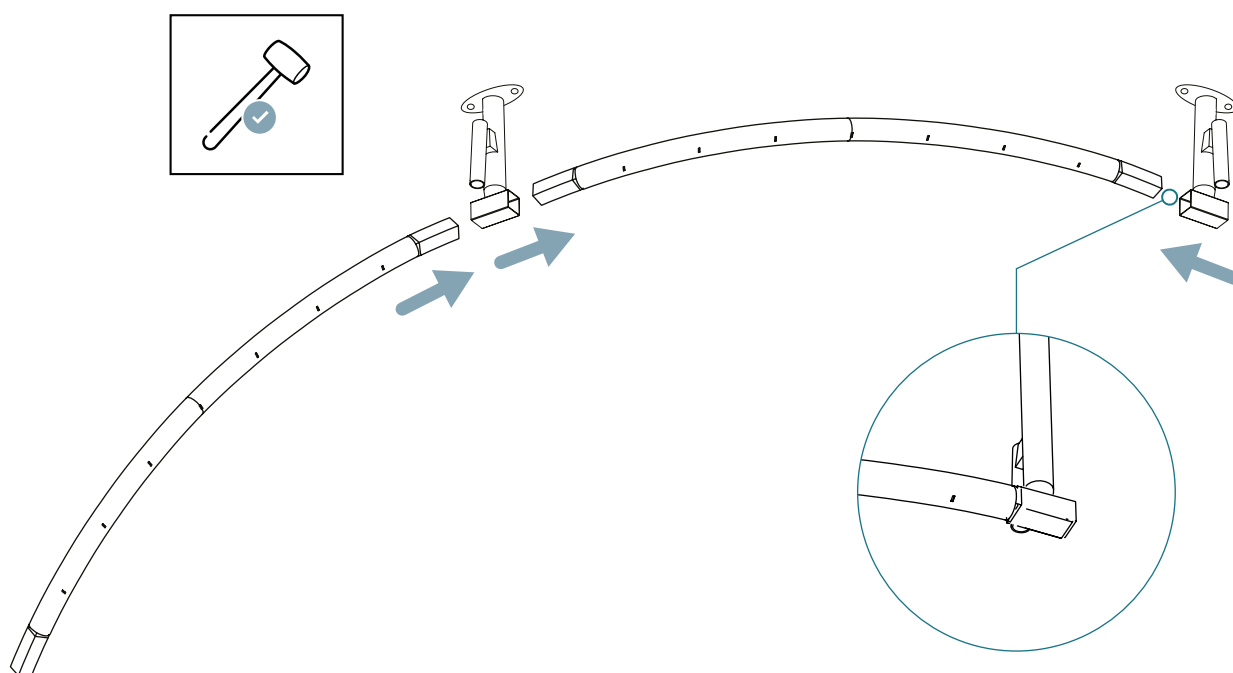
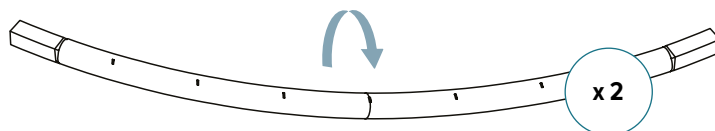
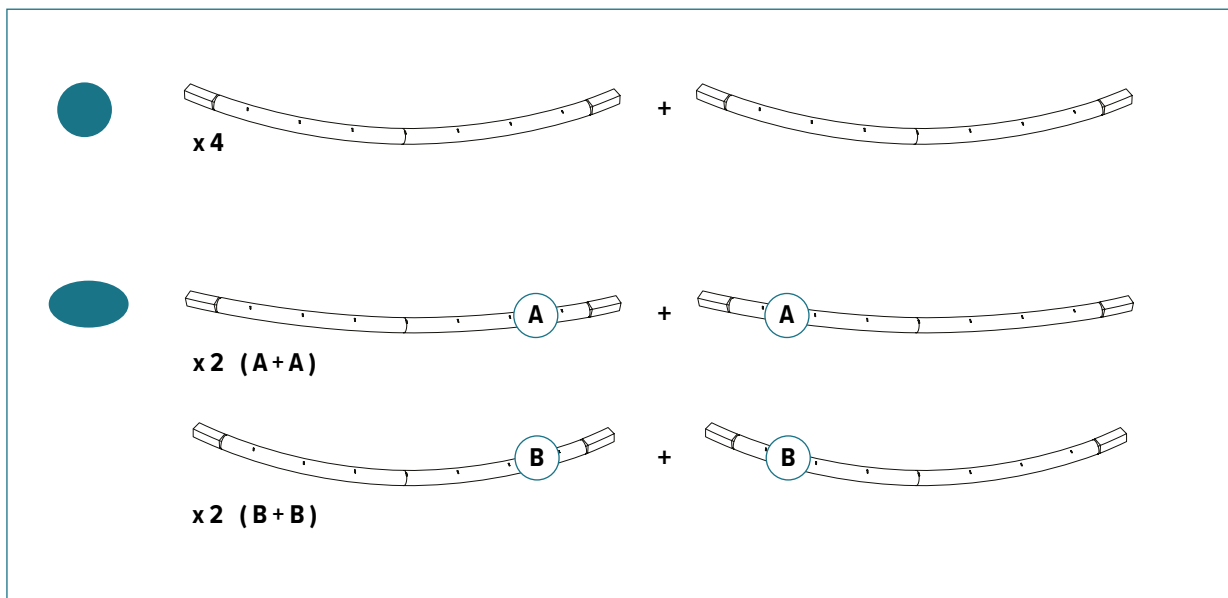
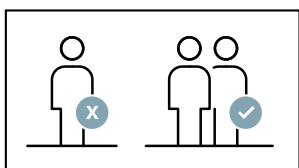
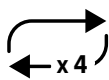

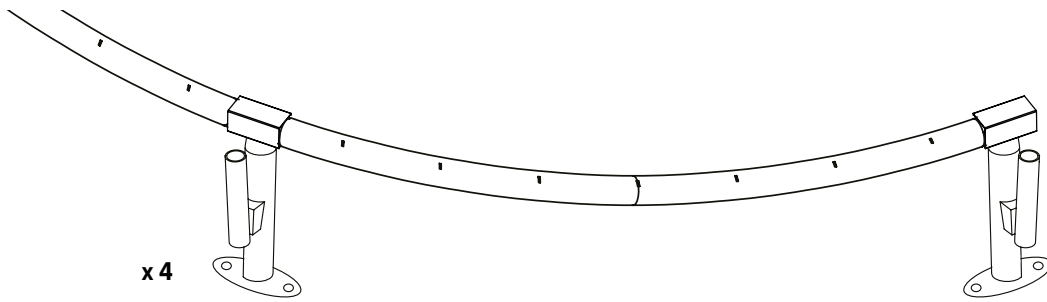
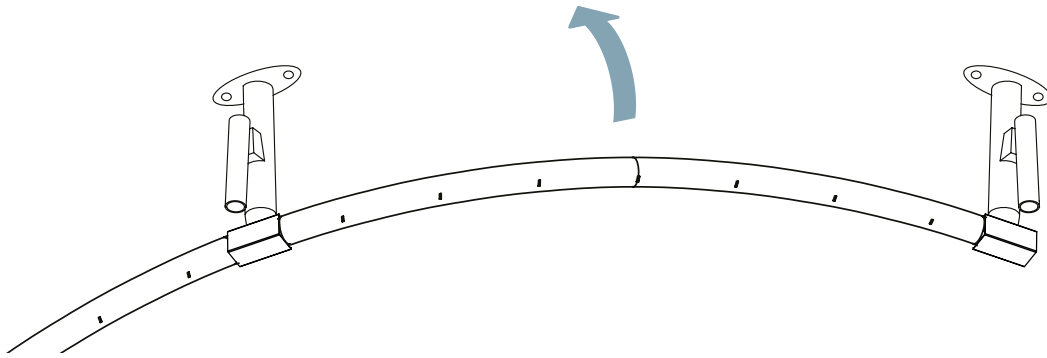

2

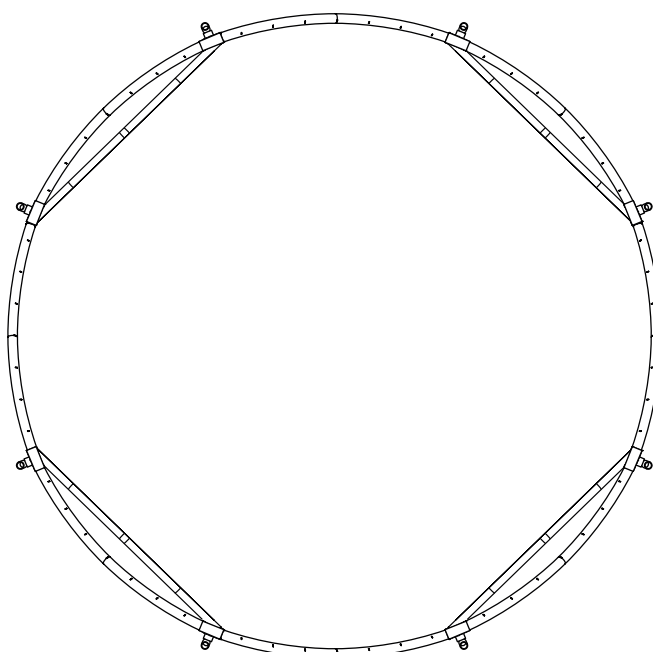
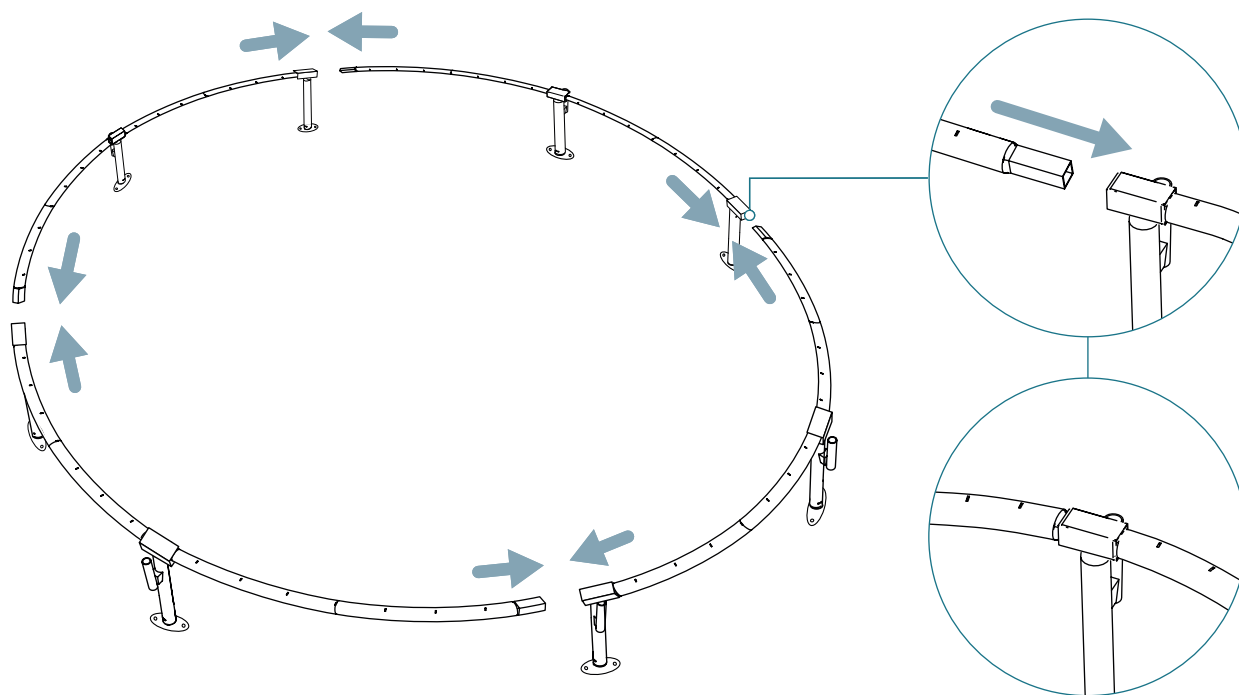
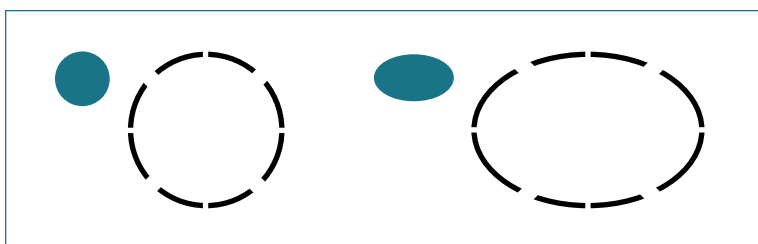
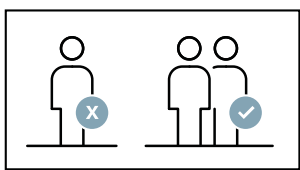

3

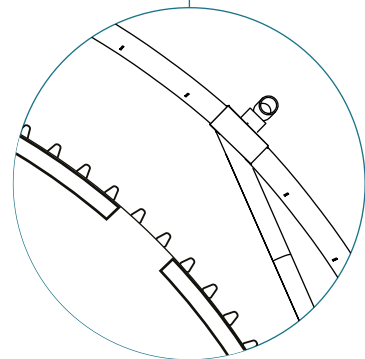
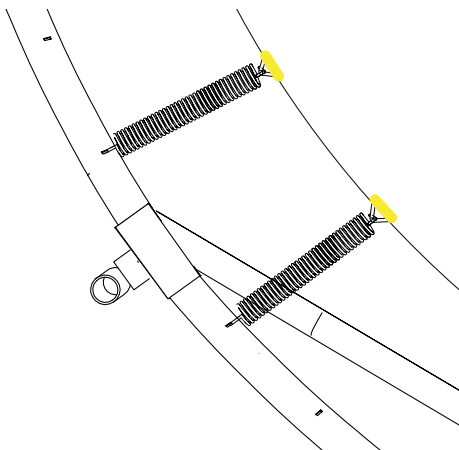
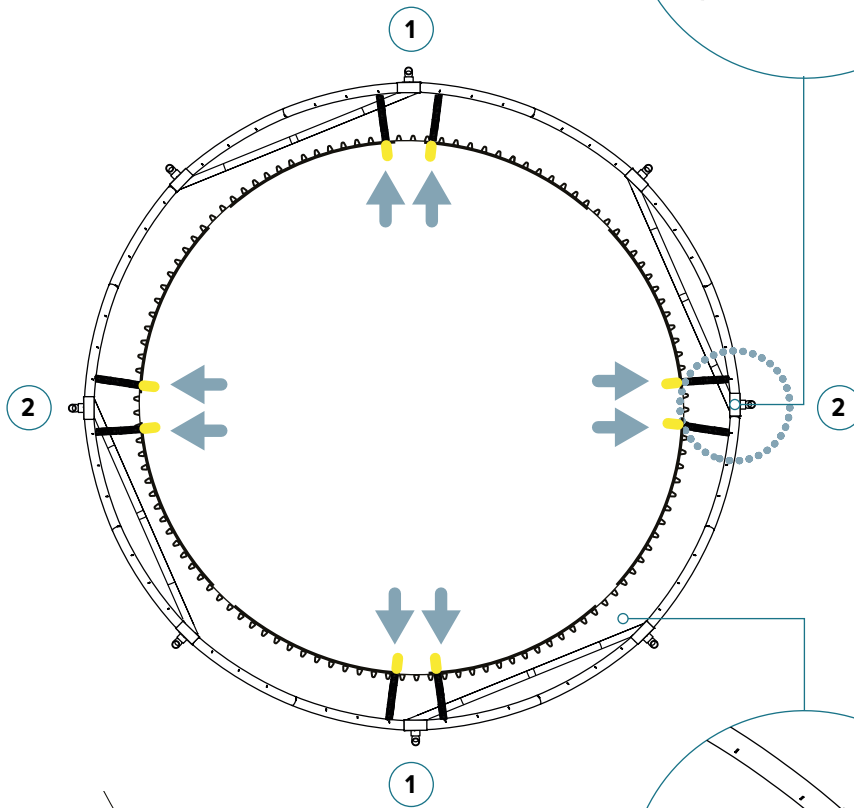
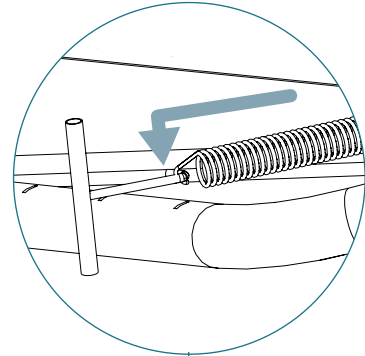
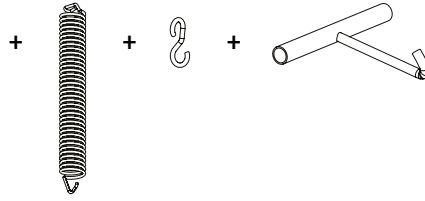
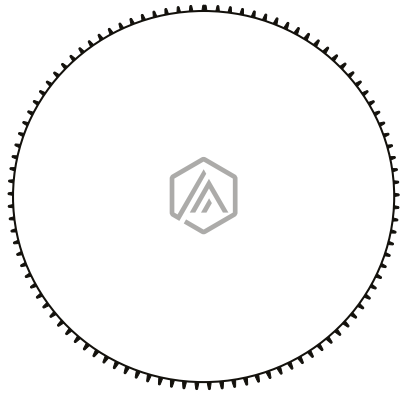

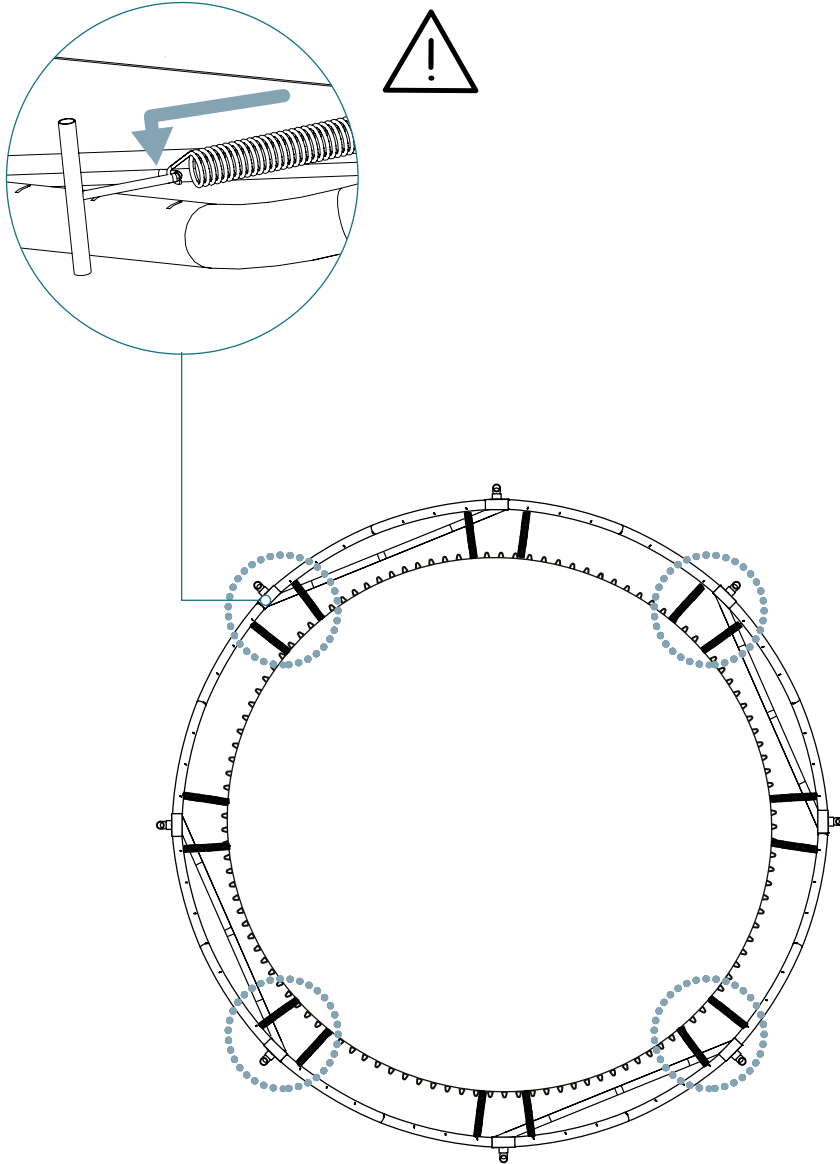

4



x 0



x 32 | x 40 | x 48



x 64 | x 80 | x 96

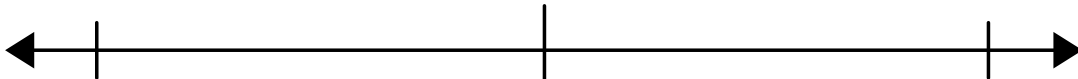

-

0

+

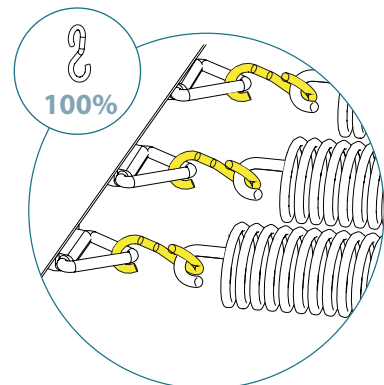
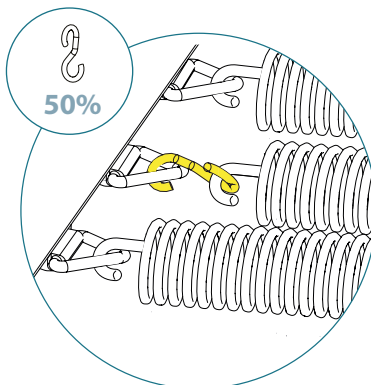
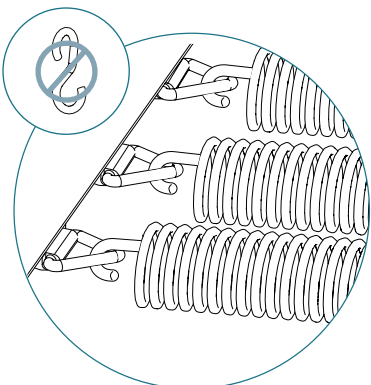
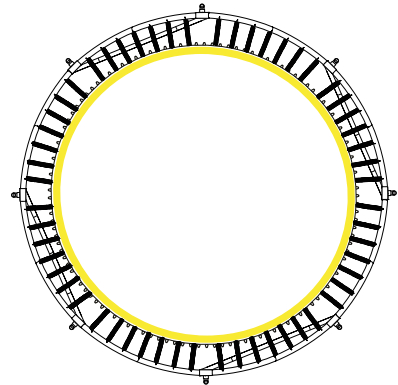
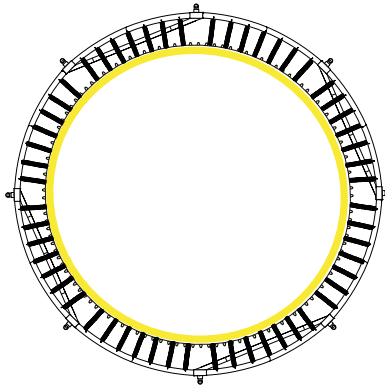
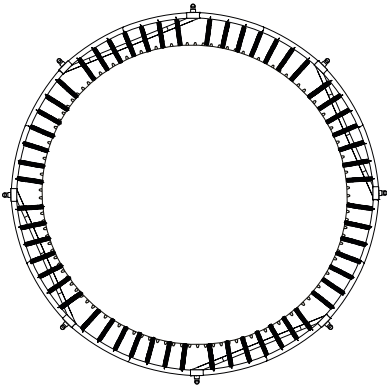



x 64 | x 80 | x 96

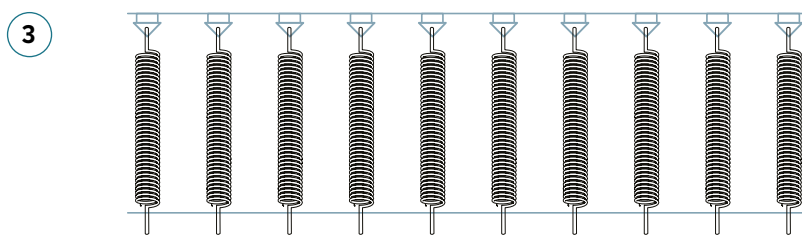
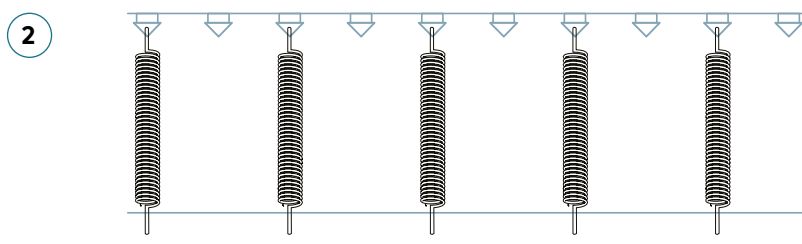
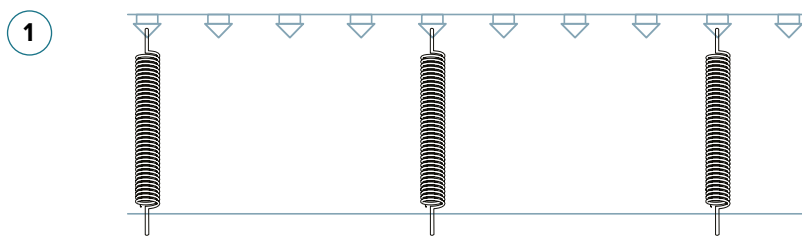
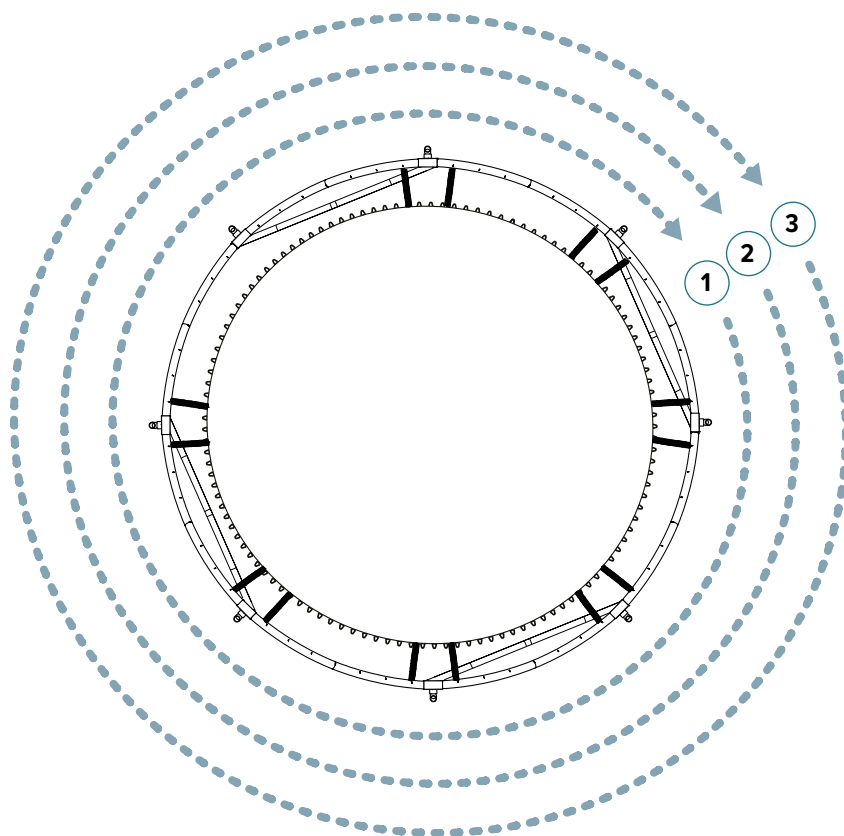



ENG

DO NOT dig before assembling springs and jump mat. The frame contracts and dimensions are altered.

SV

Gräv INTE innan fjädrar och hoppduk blivit monterade. Ramen drar ihop sig under montering.

NO

Grav IKKE før fjærer, og hoppeduk er montert. Rammeverket vil trekkes sammen ved montering.

DK

Grav IKKE hullet før I har monteret fjedre og hoppedug da rammen trækker sig sammen ved montering.

FI

ÄLÄ mittaa ja kaiva ennen kuin olet koonnut jouset ja hyppymaton. Runko menee kasaan ja mitat muuttuvat.

DE

NICHT messen und Grube ausheben vor dem Zusammenbau von Federn und Sprungtuch. Die Rahmenabmessungen ändern sich bei der Montage.

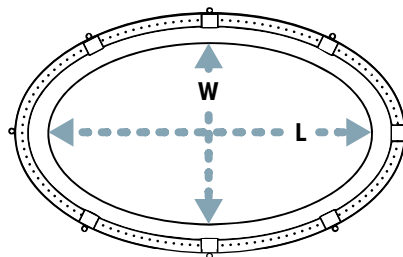
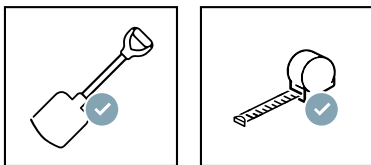

	L	W
300:	2,5 m	2,5 m
350:	3,0 m	1,9 m
360:	3,1 m	3,1 m
420:	3,7 m	2,4 m
430:	3,8 m	3,8 m
500:	4,5 m	2,9 m

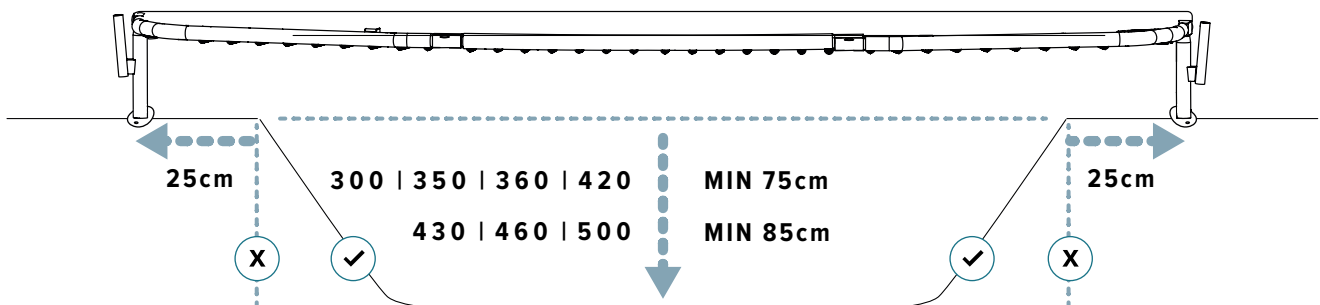

6

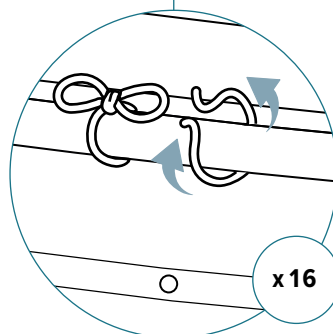
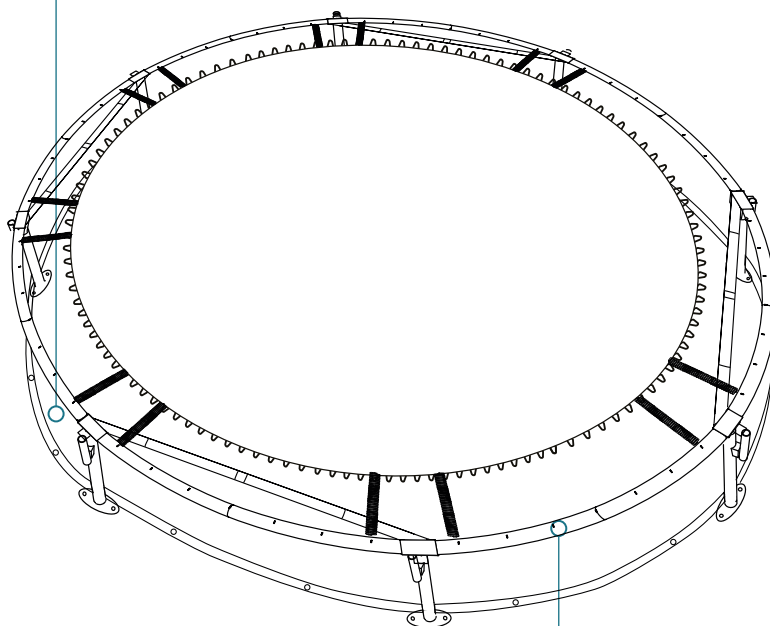
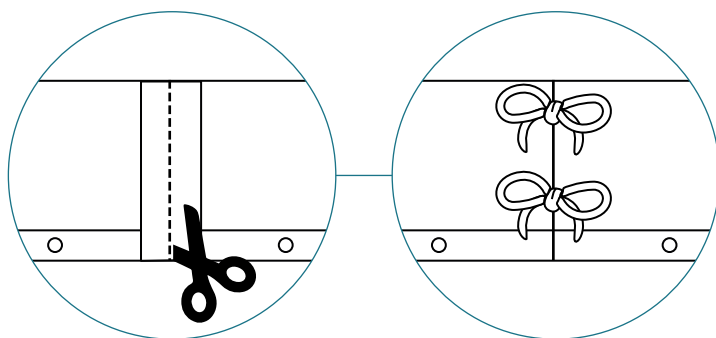
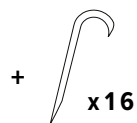
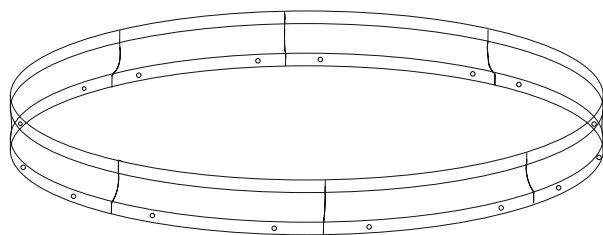

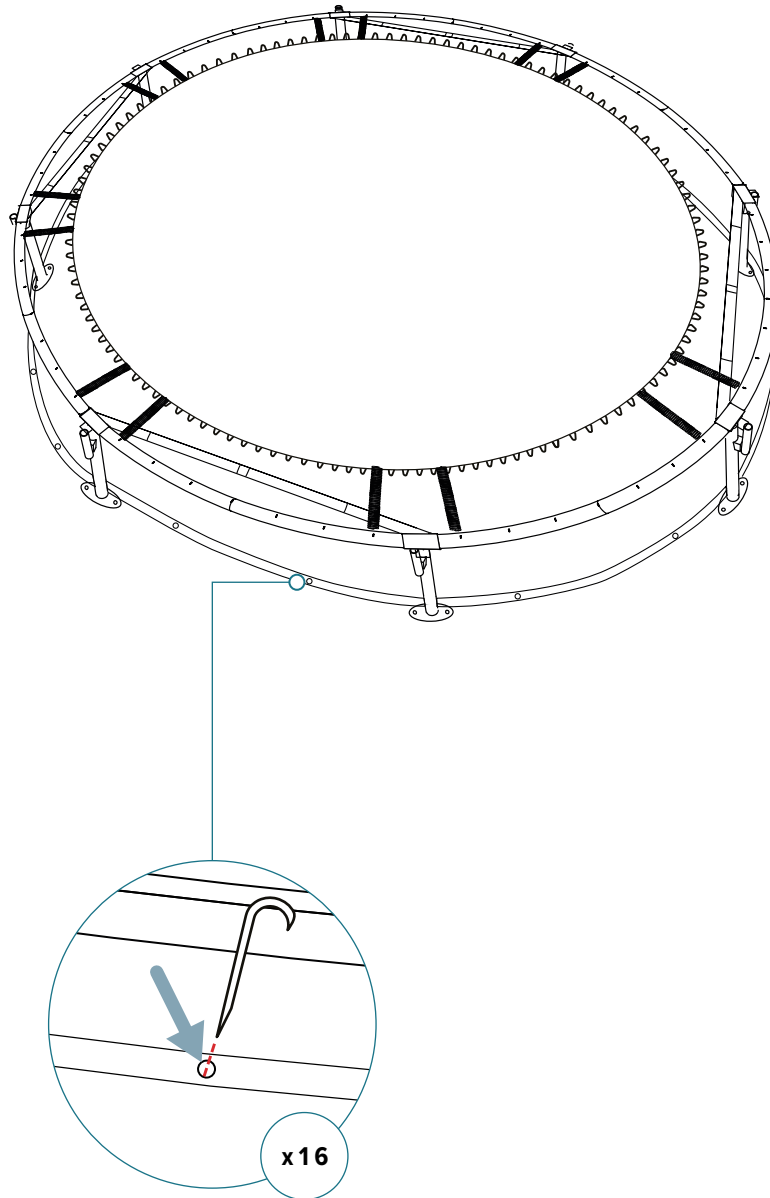

7

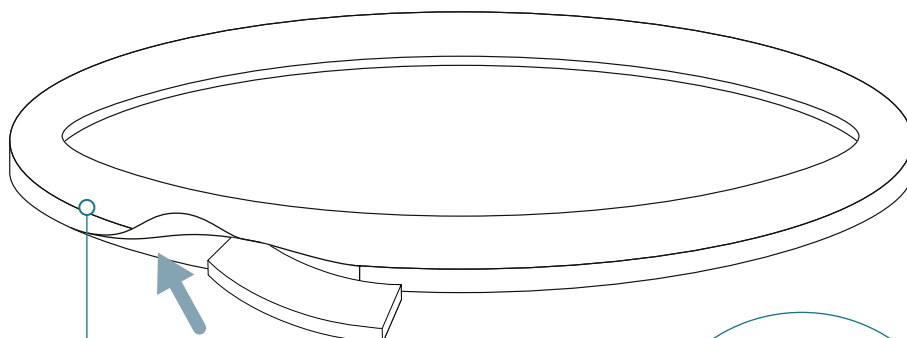
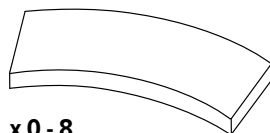

x 0 - 8

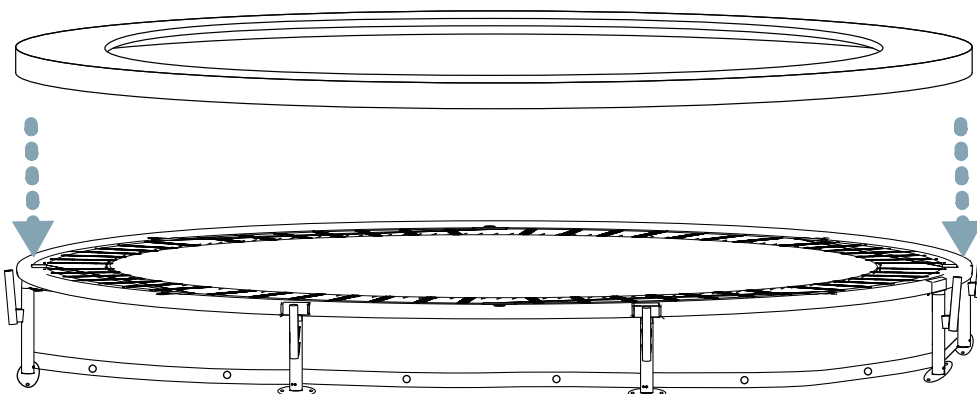
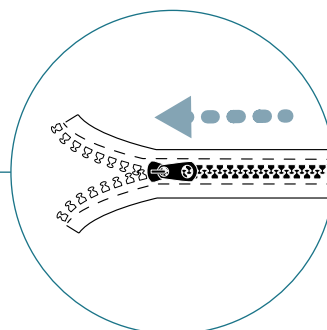

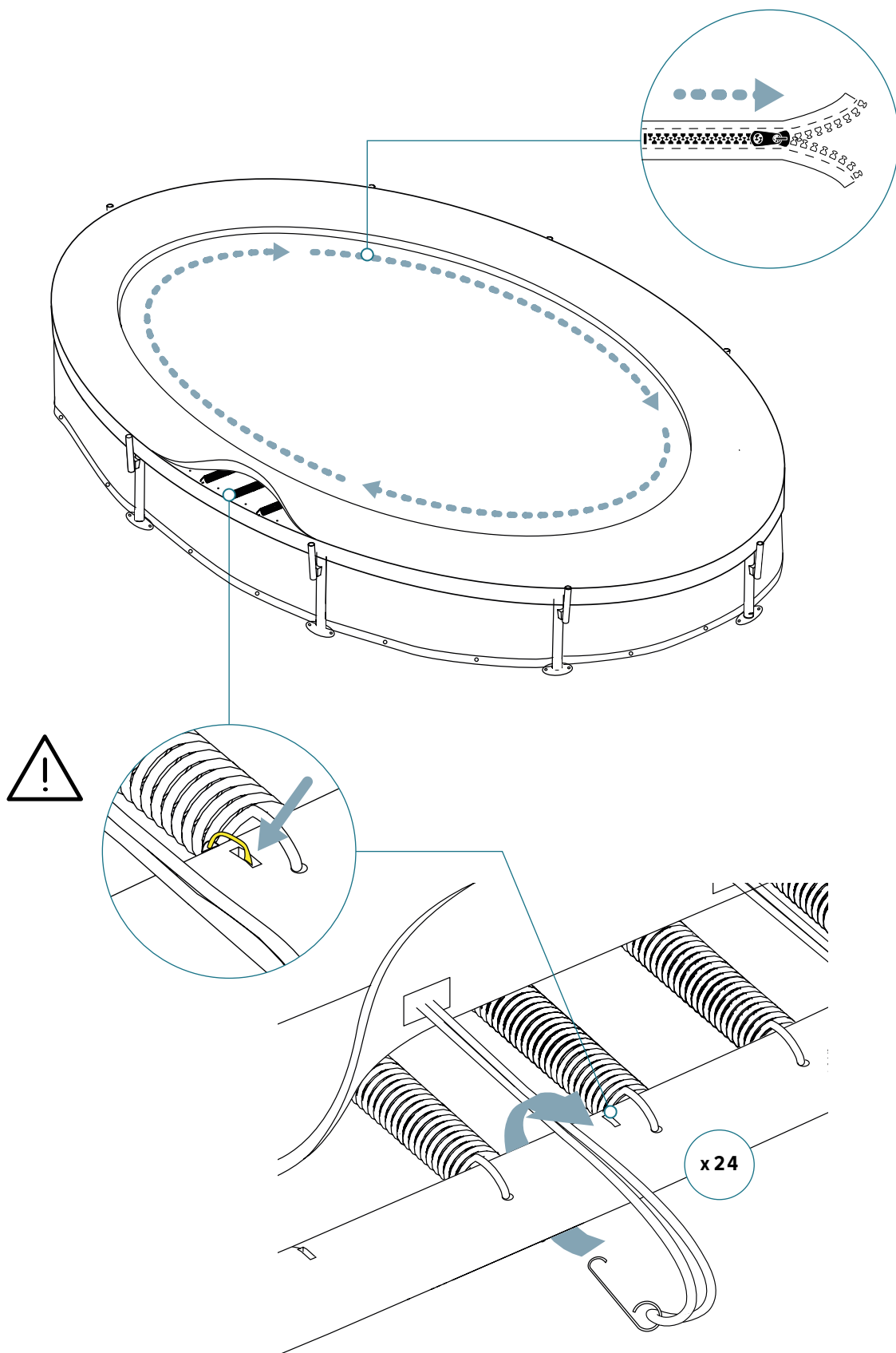

8

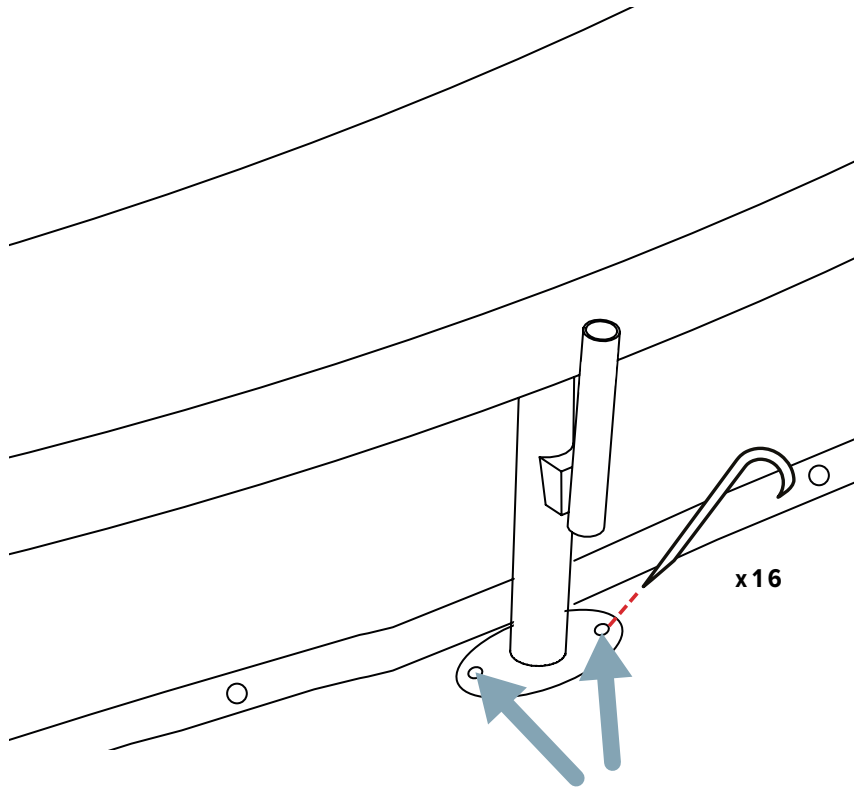

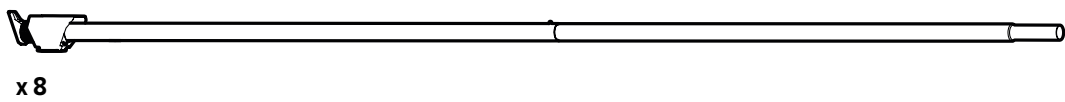
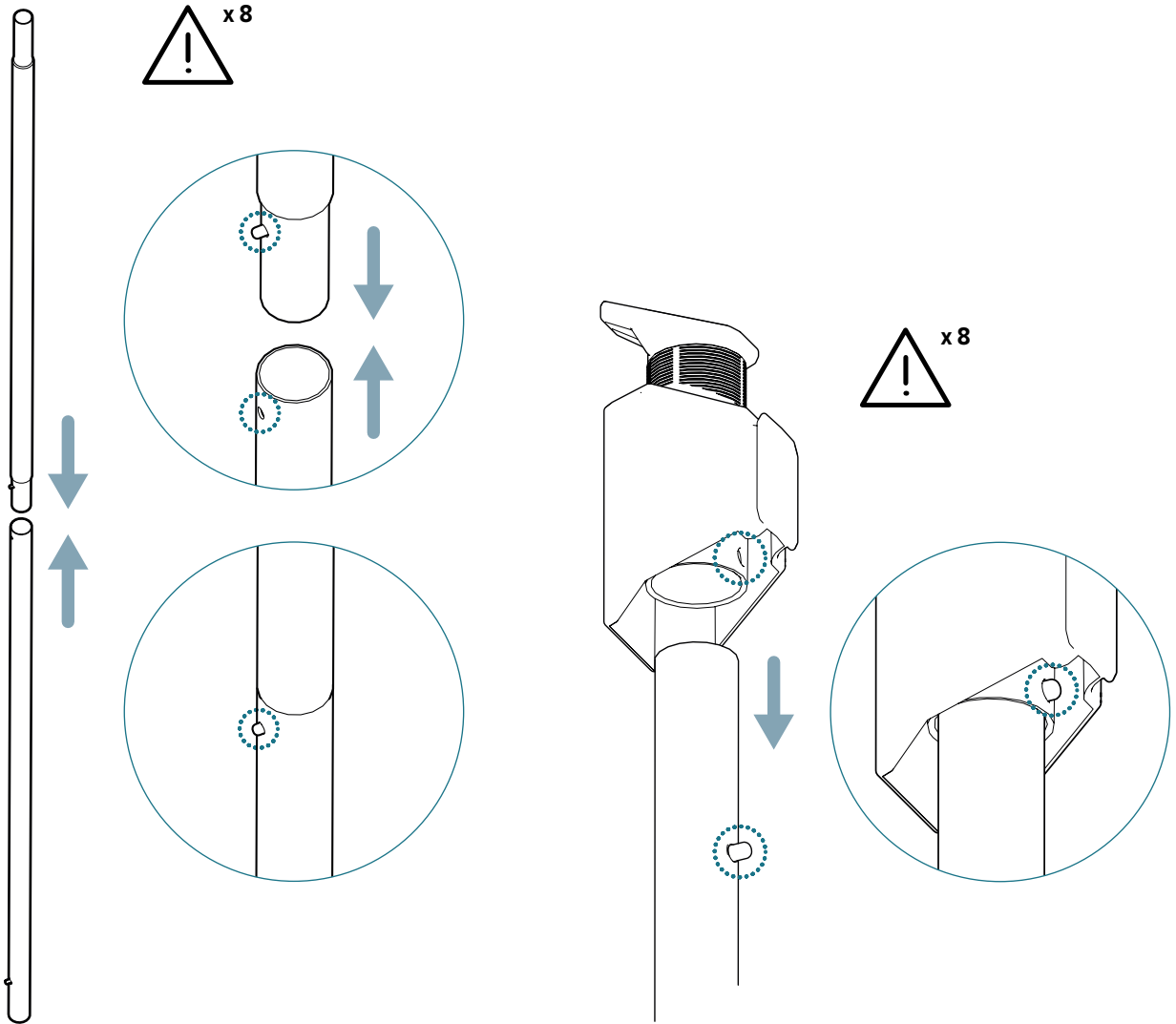

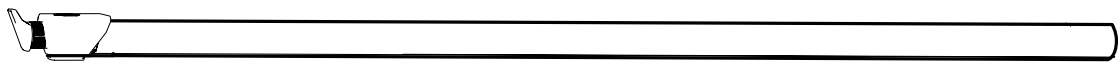
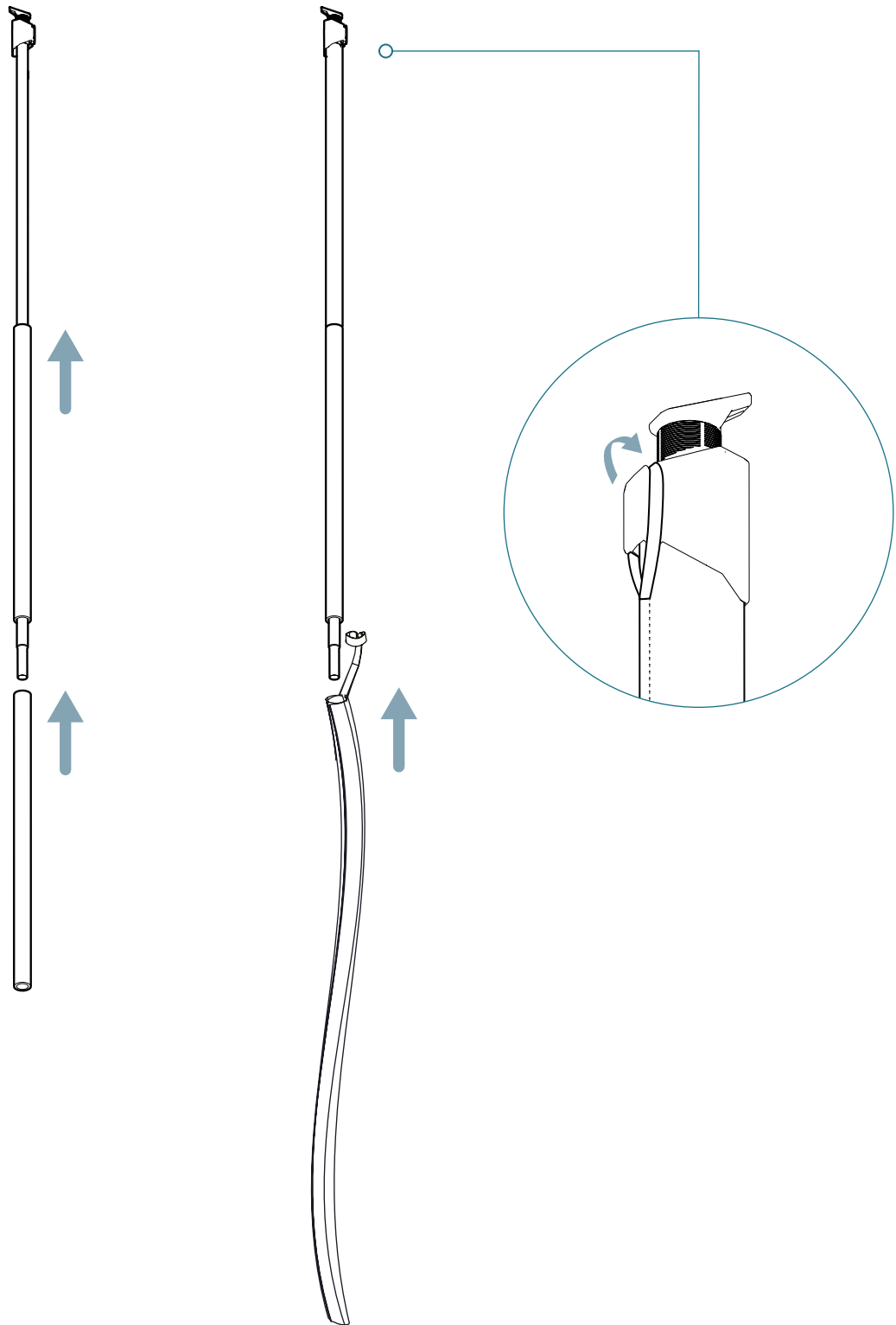

x8

10

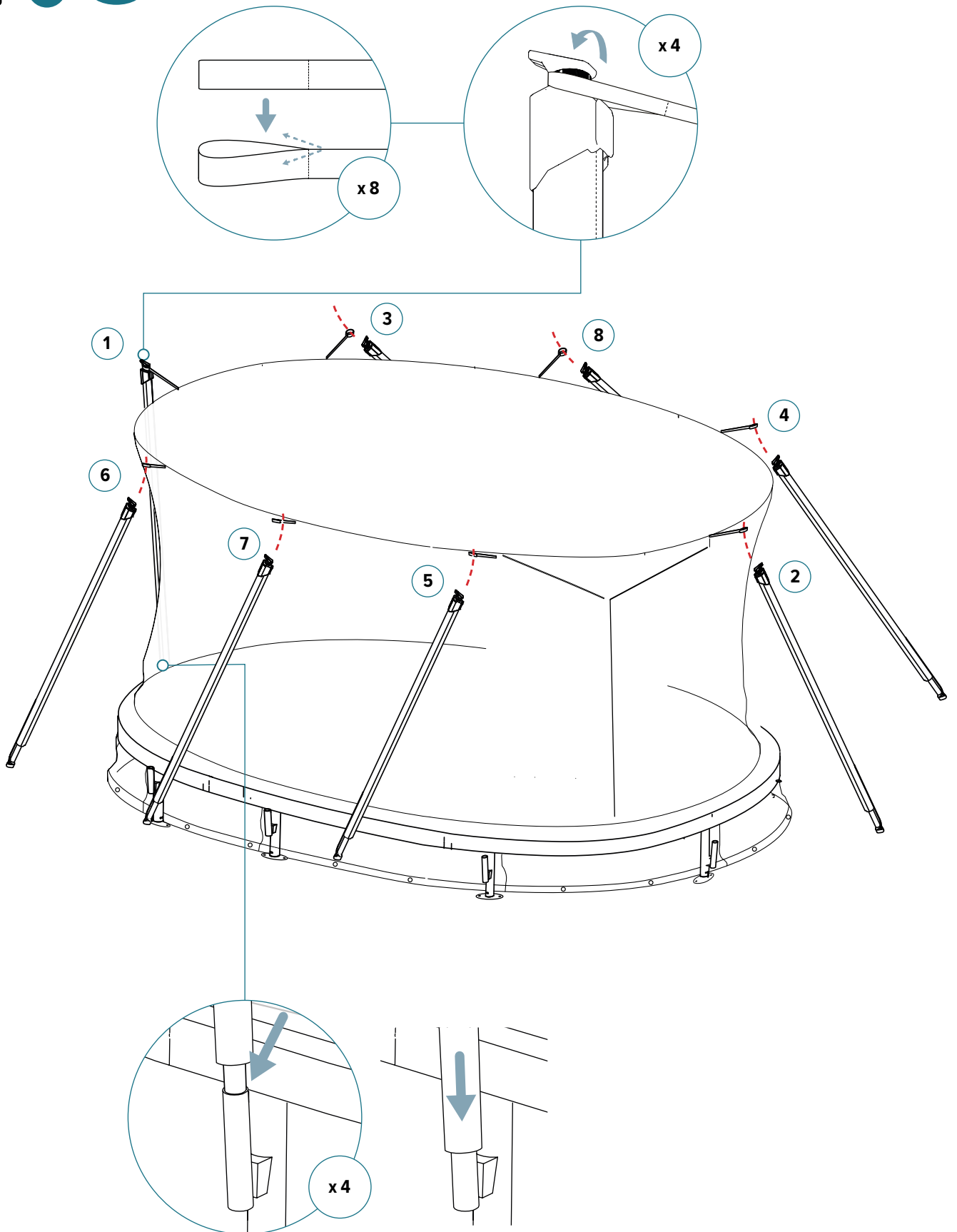

8

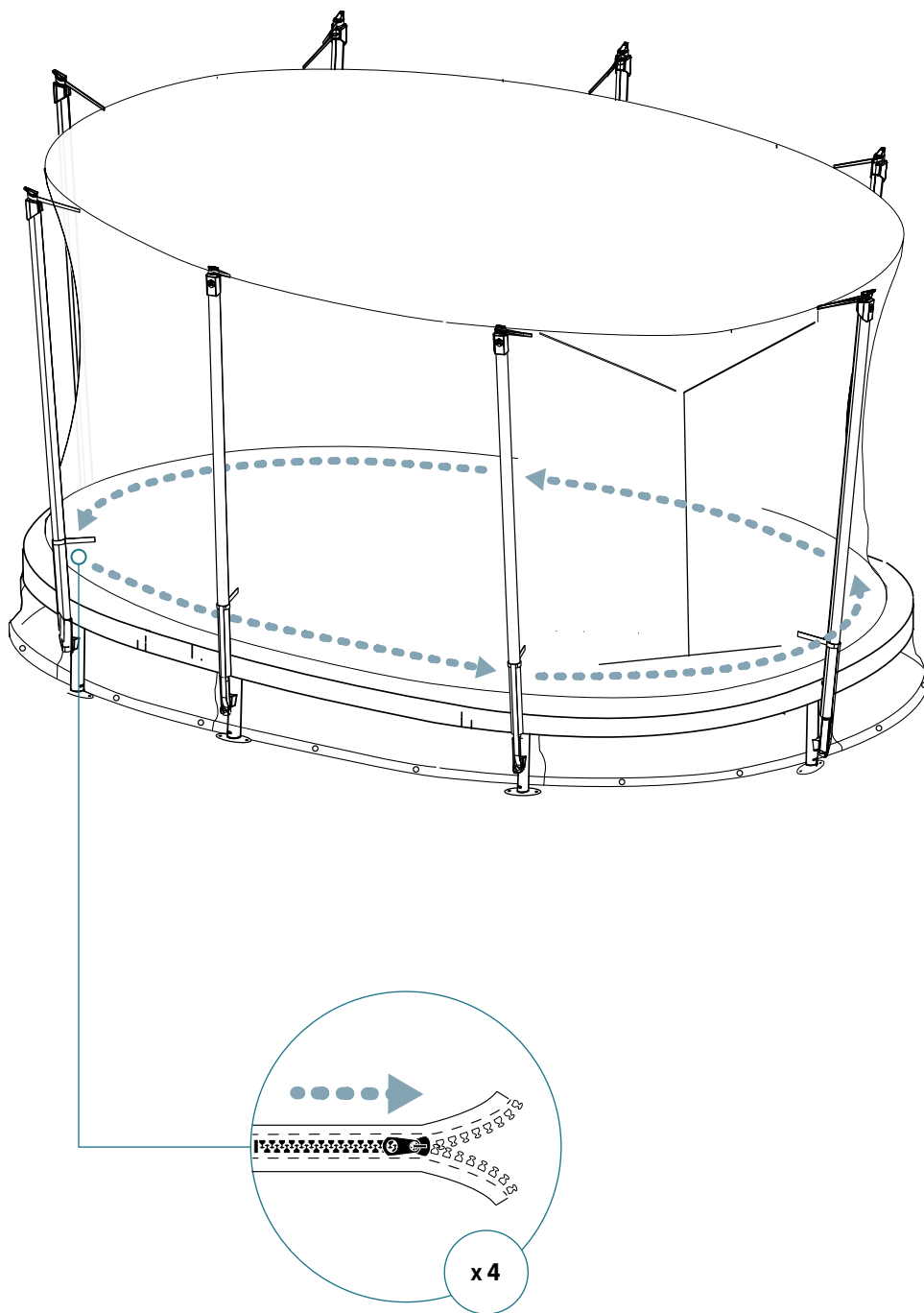

9

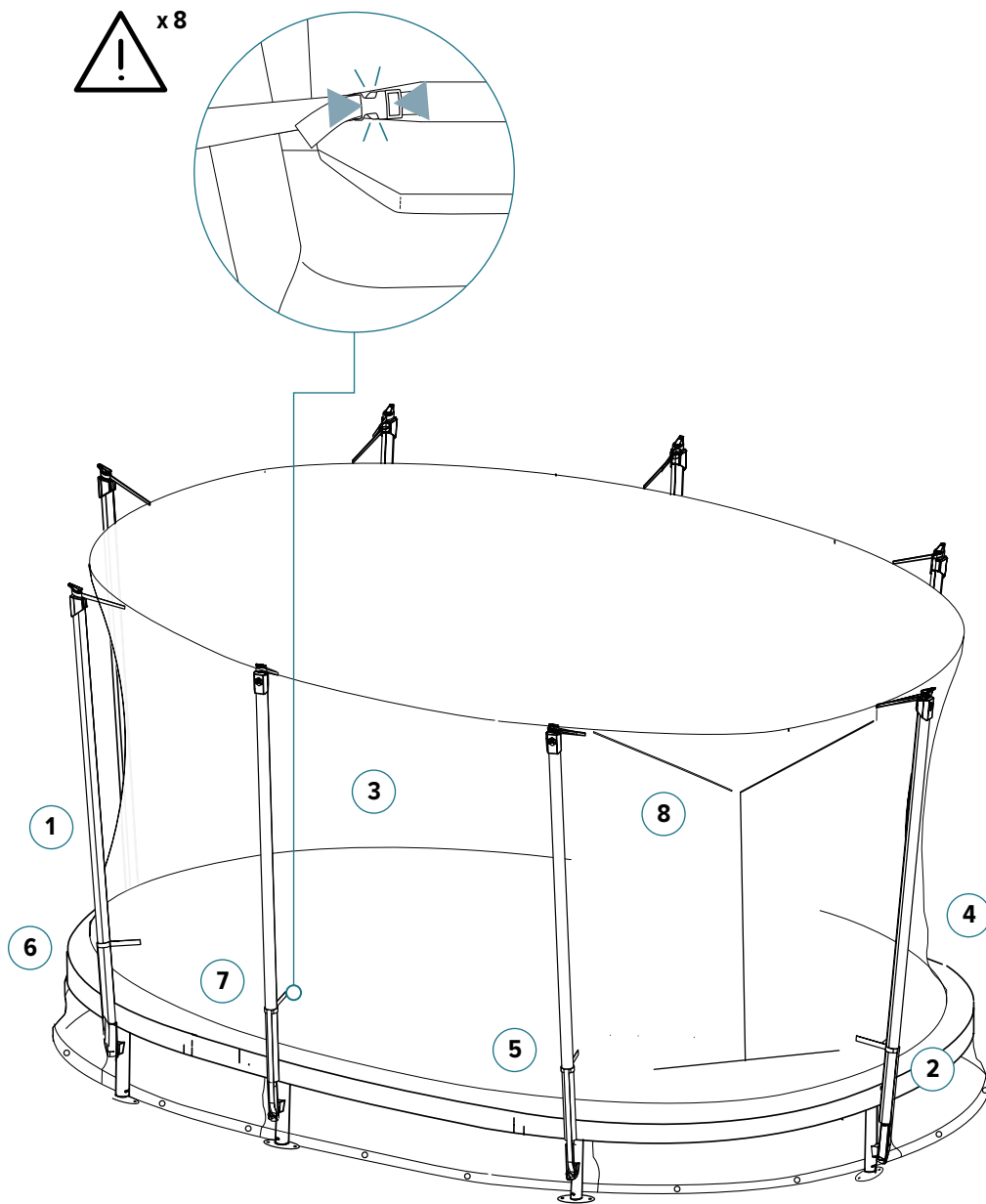

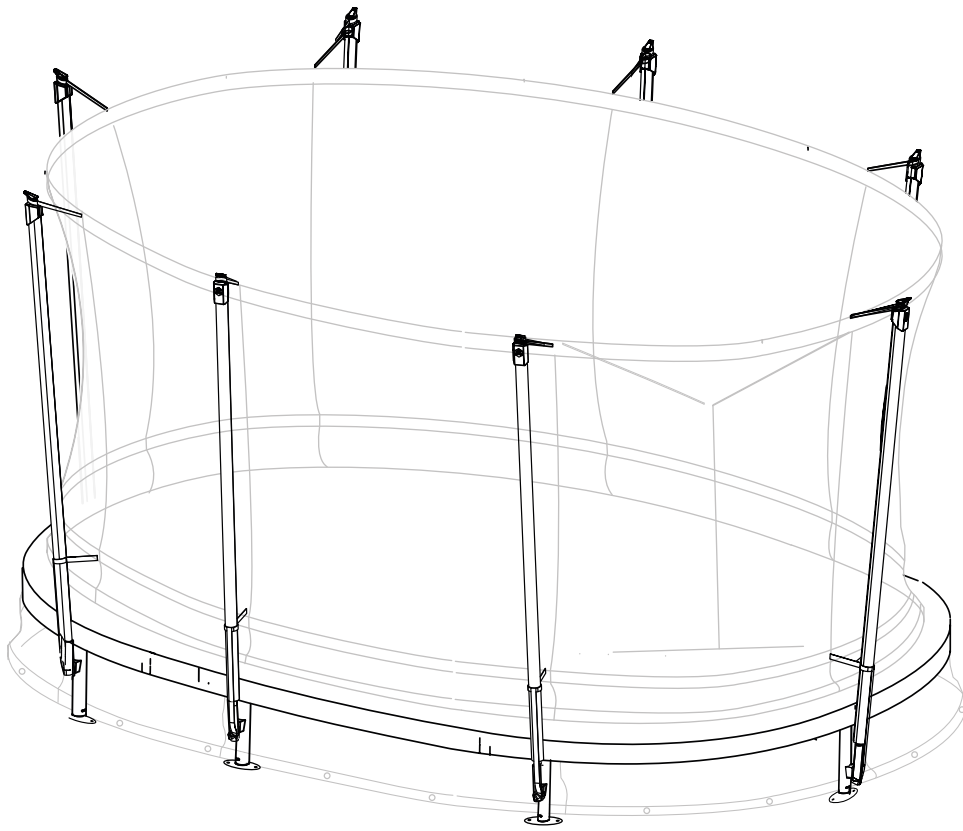

DISASSEMBLY INSTRUCTIONS

**ENG:
DISASSEMBLE**

To disassemble the trampoline, follow the assembly steps in reverse order. Do not attempt to disassemble any trampoline frame components before the springs and the trampoline mat have been removed. Use gloves to protect your hands from pinch points during disassembly.

**SV:
NEDMONTERING**

För att nedmontera studs mattan/skyddsnätet, följ de olika stegen för montering i omvänd ordning. Försök inte att nedmontera någon del av studs mattans ram innan fjädrarna och hoppduken har avlägsnats. Använd handskar för att skydda dina händer från klämmas under nedmonteringen.

**NO:
DEMONTERING**

For å demontere, følg monteringsstrinn i omvendt rekkefølge. Ikke forsøk å demontere noen rammekomponenter på trampolinen før fjærene og hoppeduken er fjernet. Bruk hansker for å beskytte hendene for klemskader ved demontering.

**DK:
NEDMONTERING**

For at demontere trampolinen/sikkerhedsnettet skal man følge trinen i modsat rækkefølge. Forsøg ikke at demontere nogen af trampolinrammens dele, før fjedre og hoppedug er blevet fjernet. Bær handsker for at undgå at få klemte fingrene under demonteringen.

**FI:
PURKAMINEN**

Pura trampoliini seuraamalla kokoamisvaiheita päinvastaisessa järjestyksessä. Älä yritä purkaa trampoliinin rungon osia ennen kuin jouset ja trampoliinimatto on poistettu. Käytä käsineitä suojataksesi kätesi puristuskohdilta purkamisen aikana.

**DE:
DEMONTAGE**

Zur Demontage des Trampolins/Sicherheitsnetzes befolgen Sie einfach die Montageschritte in umgekehrter Reihenfolge. Versuchen Sie keinesfalls, ein Rahmenteil des Trampolins zu demontieren, bevor Sie die Federn und das Sprungtuch entfernt haben. Tragen Sie Handschuhe, um ihre Hände während der Montage vor Quetschungen zu schützen.



CONTACT

North Trampoline
Rullagergatan 9
415 05 Gothenburg
Sweden

ONLINE

info@northtrampoline.com
www.northtrampoline.com